

AQUEA

V-LOCK LID

INSTALLATION & CARE GUIDE

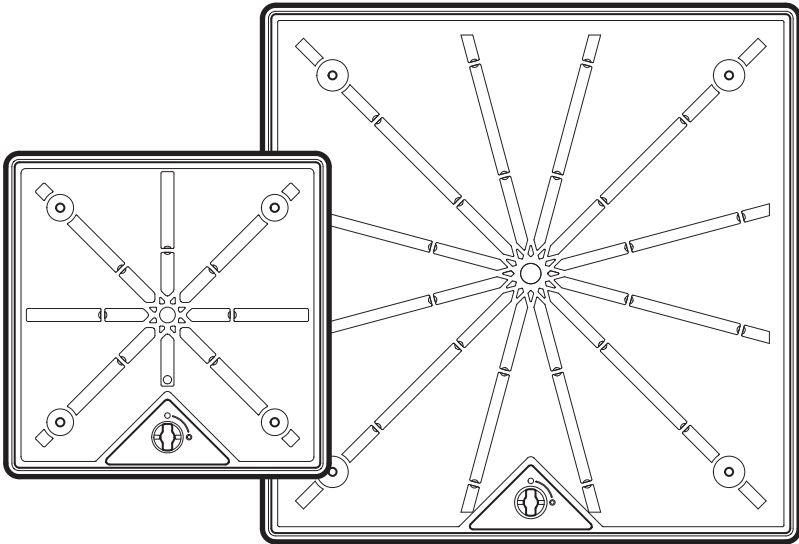

S-SERIES PART NO. 475-219 | 475-221

M-SERIES PART NO. 475-227 | 475-229

VS COMBO KIT PART NO. 475-237 | 475-238

V-SERIES PART NO. 475-201 | 475-203 | 475-205 | 475-207

⚠ NOTE:

1. READ THIS DOCUMENT PRIOR TO INSTALLATION. IMPROPER INSTALLATION WILL VOID WARRANTY.
2. PRODUCT ONLY TO BE INSTALLED & SERVICED BY A SUITABLY QUALIFIED PROFESSIONAL.
3. DO NOT USE ACID/CHEMICAL WASHES. DISCOLORATION MAY OCCUR AND WILL VOID WARRANTY.
4. INSTALLER TO ENSURE INSTALLATION MEETS ALL APPLICABLE ENGINEERING & REGULATORY REQUIREMENTS.
5. DO NOT CARRY LID WITH KEY.
6. ALWAYS REMOVE KEY FROM LID ONCE LOCKED. KEEP KEY OUT OF REACH OF CHILDREN.
7. THIS MANUAL CONTAINS IMPORTANT INFORMATION. ONCE INSTALLATION IS COMPLETE INSTALLER MUST PROVIDE THIS MANUAL TO OWNER/OPERATOR TO STORE IN A SAFE PLACE.

IMPORTANT - PLEASE NOTE:

1. SEE "GENERAL USAGE" SECTION FOR INSTRUCTIONS REGARDING CORRECT OPERATION OF LID (SEE PAGE 9)
2. DO NOT CARRY LID WITH LID KEY AS THIS MAY RESULT IN INJURY OR DAMAGE
3. DO NOT USE HARSH CHEMICALS, ACIDS OR ABRASIVE MATERIALS TO CLEAN LID, OUTER FRAME OR LID KEY
4. KEEP LID KEY OUT OF REACH OF CHILDREN. LID SHOULD ONLY BE OPERATED BY A CAPABLE ADULT
5. ENSURE FINGERS & TOES ARE CLEAR OF LID WHEN LOWERING TO AVOID INJURY
6. DO NOT OPEN SKIMMER WHILE PUMP IS OPERATING
7. DO NOT LEAVE LID KEY IN LID WHEN NOT IN USE. STORE LID KEY IN A SAFE PLACE
8. FOR SMOOTH AND RELIABLE OPERATION, KEEP YOUR V-LOCK LID FREE OF DIRT, SAND, LEAF MATTER AND DEBRIS



SAFETY FIRST

PLEASE ENSURE SUITABLE PERSONAL PROTECTION EQUIPMENT AND SAFE WORK PRACTICES ARE USED.

ALL V-LOCK LIDS ARE COVERED BY A 5 YEAR WARRANTY

See "WARRANTY POLICY" for further information

Ref: 475-818-06

Registered Design. Specifications subject to change without notice.

AQUEA® is a trademark of AQUEA Pty. Ltd.

The contents of this manual are the exclusive copyright of AQUEA® and may not be reproduced without written permission. © 2025

Whilst every care was taken in preparation of this document, AQUEA® accepts no responsibility for the accuracy of the information supplied.

KIT CONTENTS

NOTE: VS20 & VS30 Combo Kits include a single Lid Key

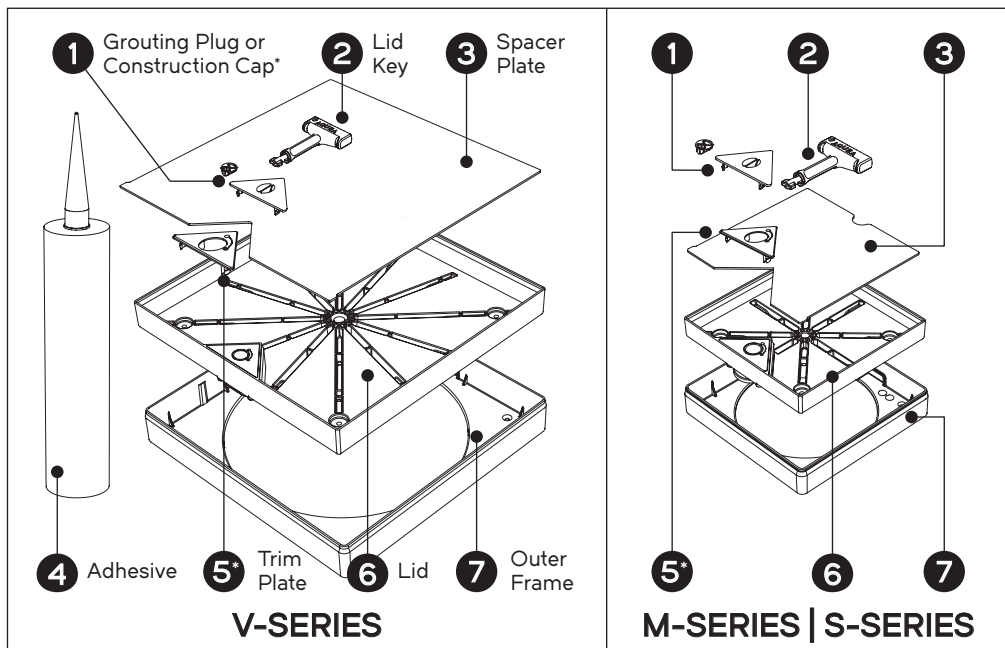

*Included in kits with colour matched polymer trim plate only

KEY DIMENSIONS

MODEL		S20	S30	M20	M30	V10	V15	V20	V30
OUTER FRAME	Overall Depth	37.0	47.0	33.0	43.0	26.0	32.0	37.0	47.0
	Overall Width	206.0		305.0		342.0			
	Overall Length	206.0		305.0		342.0			
LID	Internal Lid Depth	23.0	33.0	23.0	33.0	12.0	18.0	23.0	33.0
	Inlay Thickness Range	15~22	25~32	15~22	25~32	8~11	12~16	15~22	25~32
	Overall Inlay Width	185.0		281.0		322.0			
	Overall Inlay Length	185.0		281.0		322.0			
All dimensions in millimeters. Tolerance +/- 1.0mm									

FEEDBACK & SUGGESTIONS

We are continually looking for ways to improve and expand our product range. Please contact us at hello@aquea.com.au if you have any feedback or suggestions!

OUTER FRAME PREPARATION - STONE/TILE

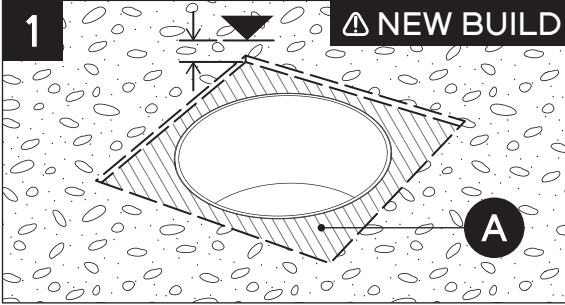

NEW BUILD

- Check & confirm finished height of stone/tile.
- Check & confirm overall height of V-LOCK model to be installed (See Page 2).
- Prepare a level bed slightly larger than overall size of Outer Frame including mortar bed allowance (A).

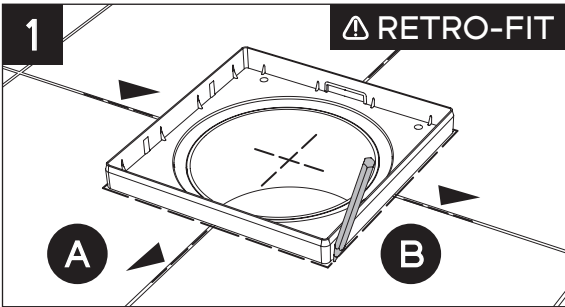

RETRO-FIT

- Align & centre Outer Frame over existing skimmer box opening (A).
- Mark perimeter of Outer Frame on surrounding stone/tile (B).

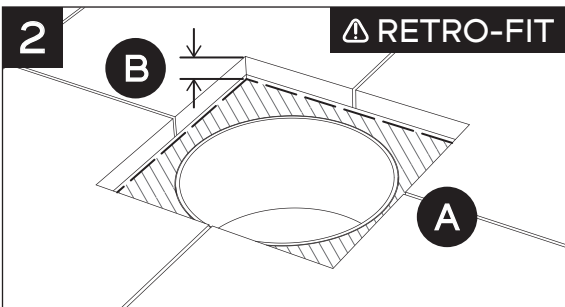

To create recess for Outer Frame:

- Carefully cut existing tile/stone to create recess for Outer Frame (A).
- Remove debris to a depth suitable for overall height of V-LOCK model to be installed (See Page 2) plus mortar bed allowance (B).

OUTER FRAME INSTALLATION - STONE/TILE

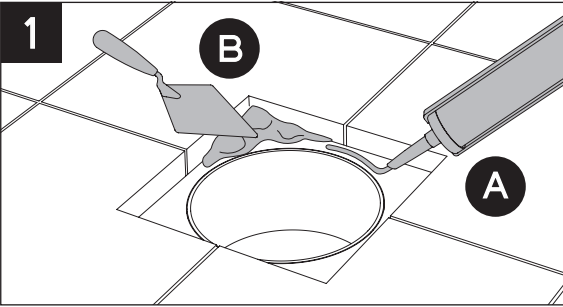

To prepare for Outer Frame install:

- Using an appropriate adhesive, apply a generous, even bead across mounting surface surrounding skimmer opening (A).
OR
- Using appropriate mortar mix, insert mortar into recess surrounding skimmer opening (B).

IMMEDIATELY REMOVE ANY MORTAR OR ADHESIVE THAT FALLS INTO SKIMMER

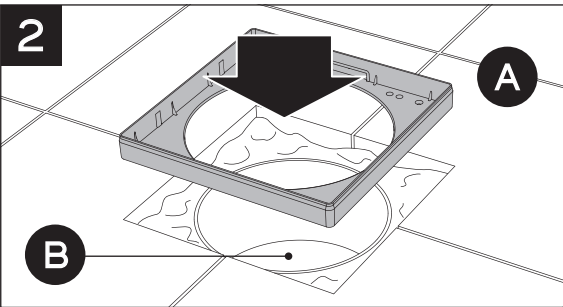

To install Outer Frame:

- Place Outer Frame on mortar or adhesive bed. Outer Frame must be fully supported (A).
- Ensure top rim of Outer Frame is flush with finished stone/paver surface.
- Remove any excess mortar/adhesive and ensure skimmer opening is fully accessible through Outer Frame (B).

IMMEDIATELY REMOVE ANY MORTAR OR ADHESIVE THAT FALLS INTO SKIMMER

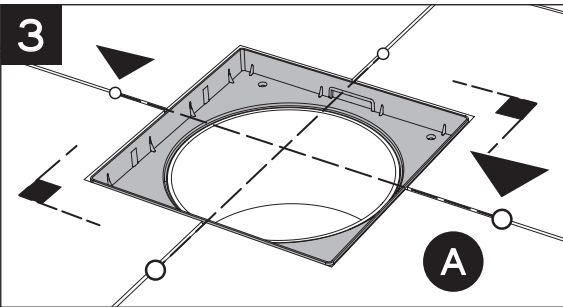

BEFORE MORTAR OR ADHESIVE IS CURED

To install Outer Frame:

- Adjust as required to ensure Outer Frame is level, square and top rim is flush with surrounding surface (A).

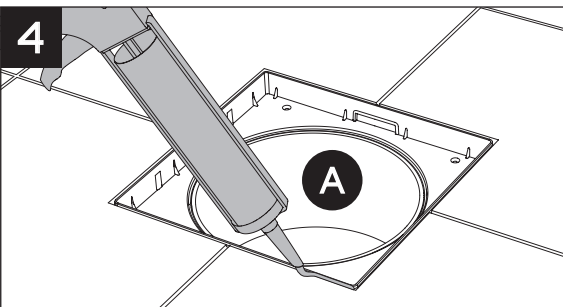

AFTER MORTAR OR ADHESIVE IS CURED

To finish Outer Frame:

- **PREFERRED** - Fill gap surrounding Outer Frame using a suitable expansion joint gap filler (A).
- **ALTERNATE** - Apply grout around Outer Frame perimeter using preferred mortar/grout compound*.

* Using rigid grout or mortar may result in gaps/cracking appearing over time due to natural expansion & contraction.

OUTER FRAME INSTALLATION - DECKING

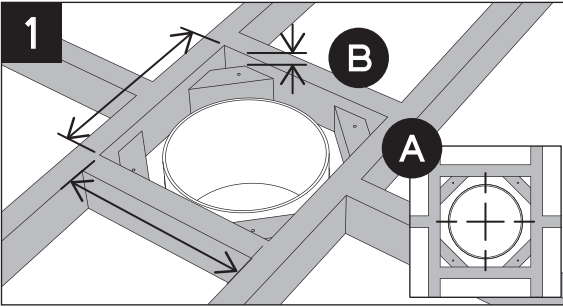

To prepare sub-frame:

- Construct square opening in sub-frame slightly larger than Outer Frame, centred over skimmer box opening (A).
- Fix corner gussets to sub-frame opening. Ensure gussets are recessed so top surface of Outer Frame rim is flush with finished decking level (B).

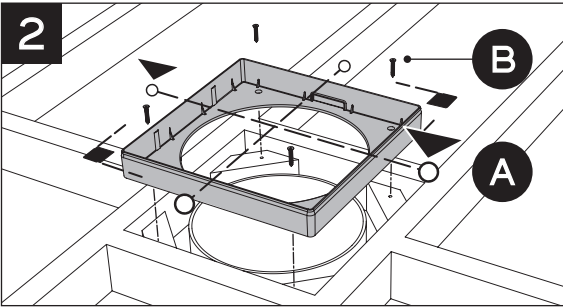

To install Outer Frame:

- Adjust as required to ensure Outer Frame is square, level and centred on skimmer box opening (A).
- Attach Outer Frame to sub-frame with suitable fasteners through pre-moulded mounting holes (B).

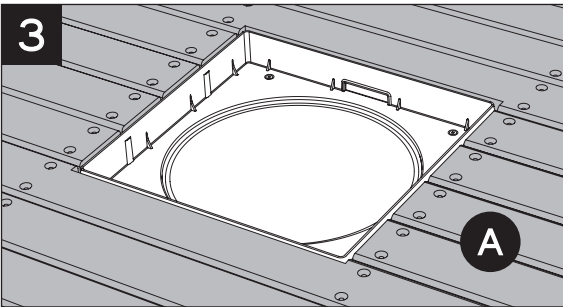

Applying decking:

- Lay decking around Outer Frame leaving a small clearance gap (A).

HINT: For a seamless installation, cut boards spanning Outer Frame so that a section equal to width of Lid is removed. These pieces can be used to create a perfectly grain-matched Lid inlay.

LID INLAY INSTALLATION - STONE/TILE

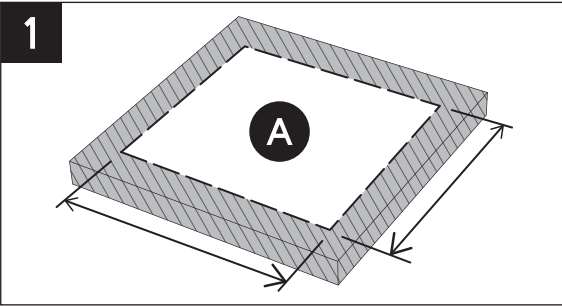

To cut inlay material to size:

- Place inlay material in desired layout on a flat surface.
- Carefully cut to correct size to suit V-LOCK Lid (A). (See Page 2)

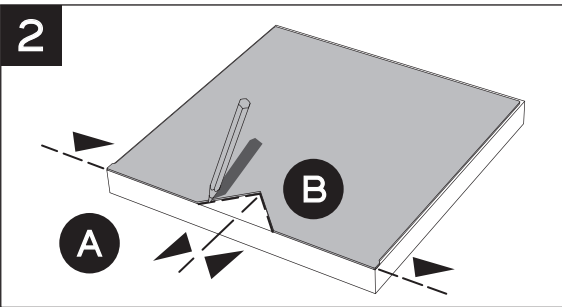

To mark V-notch cut-out:

- Place inlay material with preferred surface facing upwards.
- Position Spacer Plate on inlay material.
- Align & centre V-notch edge of Spacer Plate with selected edge of inlay (A).
- Mark V-notch cut-out profile (B).

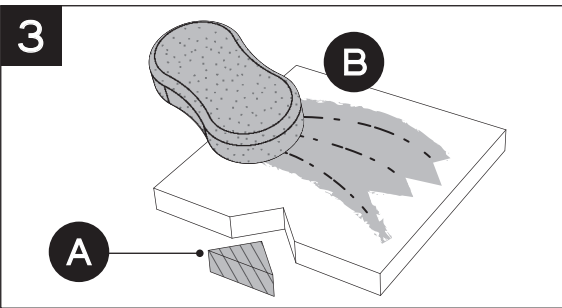

Prepare inlay for installation:

- Carefully cut and remove V-notch material from inlay (A).
- Thoroughly clean and dry inlay to maximise adhesive bond strength (B).

ENSURE INLAY IS FREE FROM DUST, OIL, DEBRIS AND COMPLETELY DRY BEFORE CONTINUING.

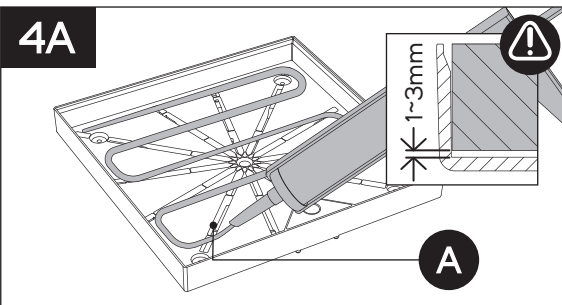

FOR INLAYS 1~3mm THINNER THAN INTERNAL LID DEPTH

To apply adhesive :

- Insert Adhesive into caulking gun & cut nozzle to provide a minimum 6mm wide bead.
- Apply a generous, even bead across entire internal surface of Lid (A).

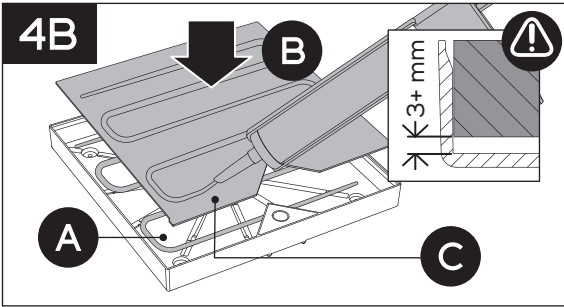

FOR INLAYS MORE THAN 3 mm THINNER THAN INTERNAL LID DEPTH

To apply adhesive :

- Insert Adhesive into caulking gun & cut nozzle to provide a minimum 6mm wide bead.
- Apply a generous, even bead across entire internal surface of Lid (A).
- Insert Spacer Plate into Lid (B).
- Apply generous, even bead across entire top surface of Spacer Plate (C).

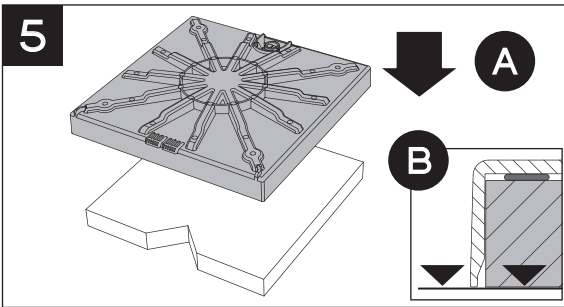

To install inlay material into Lid:

- Place inlay material face-down on a flat work surface.
- Invert Lid and lower onto inlay material (A) until Lid outer rim is touching work surface (B).

LEAVE FOR APPROXIMATELY 15 MINUTES TO ALLOW ADHESIVE TO PARTIALLY CURE.

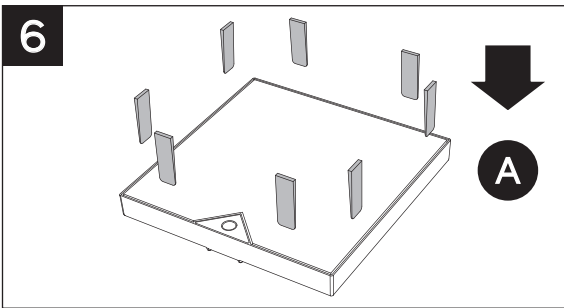

To position inlay material:

- Carefully flip Lid over and check inlay is centred for consistent grout line thickness.
- If required insert tiling wedges or similar to adjust inlay to correct position (A).

LEAVE FOR APPROXIMATELY 24 HOURS TO ALLOW ADHESIVE TO CURE FULLY.

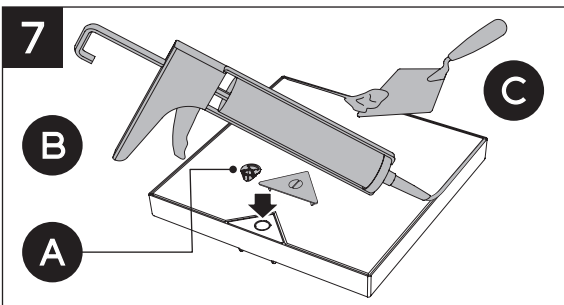

Finishing Lid:

- Insert Grouting Plug or Construction Cap to protect key opening (A).
- **PREFERRED** - Fill gap surrounding inlay using an appropriate expansion joint gap filler (B).
- **ALTERNATE** - Apply preferred mortar or grouting compound (C)*.

DO NOT USE HARSH CHEMICALS, ACID WASHES OR ABRASIVE MATERIALS TO CLEAN LID

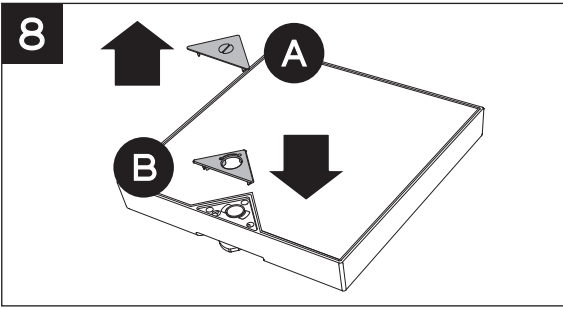

To assemble polymer Trim Plate (if required):

- Remove red Construction Cap. (A)
- Ensure key opening and surrounding recess is clean & free from debris.
- Carefully clip Trim Plate into recess. (B)

LID INLAY INSTALLATION - DECKING

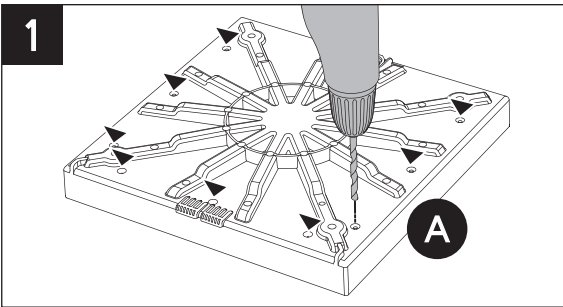

To prepare Lid for mounting battens:

- Invert Lid and select preferred mounting points for correct batten orientation.
- Drill holes in pre-moulded locations to suit preferred fasteners and batten direction (A).

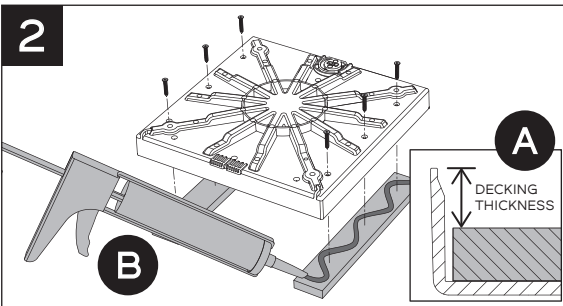

To attach battens:

- Pre-cut two timber battens ensuring batten thickness equals internal Lid depth minus decking thickness (A).
- Fasten battens into Lid using a combination of fasteners and appropriate adhesive (B).

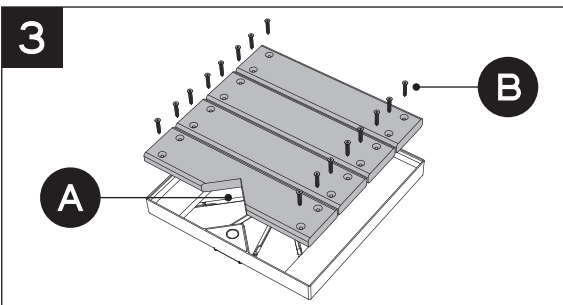

To install decking inlay:

- Pre-cut decking to fit Lid. Use Spacer Plate as template for V-notch if required (A).
- Attach decking to battens with appropriate timber fasteners (B) or adhesive.

ENSURE FASTENER LENGTH IS MINIMUM 2.0mm LESS THAN LID INTERNAL DEPTH.

GENERAL USAGE

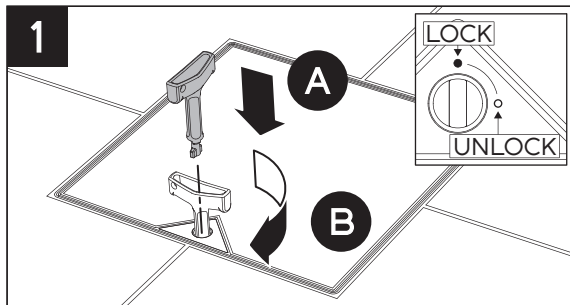

TO OPEN LID

To unlock Lid:

- Insert Lid Key into lock as shown (A).
- Rotate Key 90 degrees clockwise to unlock position. Lid Key is now captive in Lid.

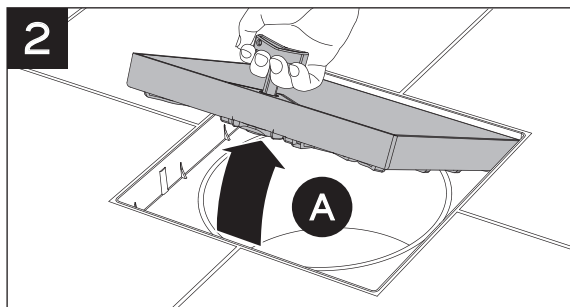

To remove Lid:

- Using Lid Key as a handle lift Lid upwards (A), then grab edges of Lid by hands and remove from Outer Frame.

DO NOT CARRY LID WITH LID KEY.

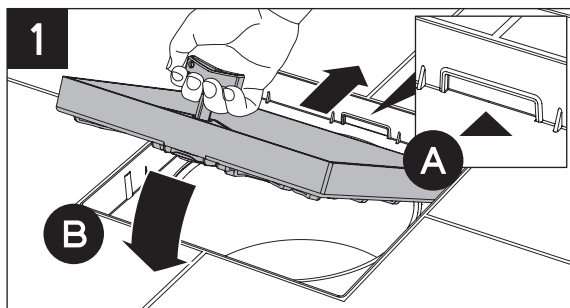

TO CLOSE LID

To close Lid:

- Angle and slide Lid's rear edge towards large pocket in Outer Frame (A).
- Engage hooks on rear edge of Lid into pocket and carefully lower Lid into Outer Frame (B).

LID MUST BE INSERTED IN CORRECT ORIENTATION TO LOCK.

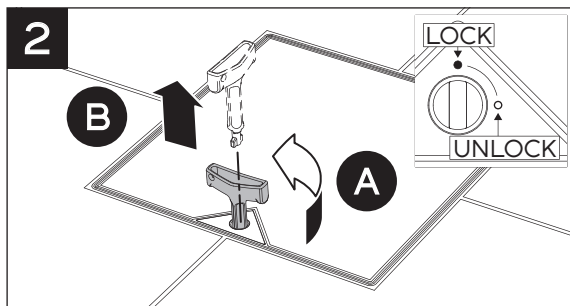

To lock Lid:

- Rotate Lid Key 90 degrees anti-clockwise to locked position, ensuring latch engages correctly in outer frame (A).
- Remove Lid Key vertically from lock and store in safe place (B).

KEEP LID KEY OUT OF REACH OF CHILDREN.

WARRANTY POLICY

AQUEA Pty. Ltd. warrants that, subject to the exclusions and limitations below, its products will be free from defects in materials and workmanship for a minimum period of 12 MONTHS from the date of purchase. All warranty periods commence on the date of purchase by the customer and are only valid in original country of purchase. The provisions of this warranty are not transferable.

If a defect appears in any Product supplied by AQUEA before the end of the Warranty Period due solely to defective materials or workmanship, AQUEA will in its sole discretion, and subject to these terms and conditions, either:

- a) repair the Product or the defective part of the Product free of charge; or
- b) have the Product or the defective part of the Product repaired by a qualified repairer free of charge; or
- c) replace the Product.

AQUEA at its sole discretion may replace defective parts of the Products with parts and components of similar quality, grade and composition where an identical part or component is not available. Refurbished parts may be used to repair the Products.

All repairs are to be carried out by AQUEA or its authorised repairer only. This warranty does not cover any costs related to travel, removal or re-installation associated with repair or replacement of the Product.

TO MAKE A WARRANTY CLAIM

To claim under this warranty the customer should immediately cease use of the Product once alleged defect is identified, and contact AQUEA within 30 days.

To make a claim the customer must:

1. Provide the following information:

- (a) proof of purchase disclosing date and place of purchase;
- (b) full details of the alleged defect; and
- (c) any other appropriate documentation.

2. The customer must make the Product or site available to AQUEA or its authorised repair agent for inspection and testing. If such inspection and testing finds no defect in the Product, the customer must pay AQUEA's usual costs of service work and testing.

3. The customer agrees to pay AQUEA's usual charges (including any service fee) for any goods or services provided by AQUEA not covered by this product warranty.

4. The customer is responsible for the cost of transport and all insurance of the Product to and from AQUEA or its authorised repair agent.

WARRANTY CONDITIONS

This warranty only applies where the following conditions are met:

1. The customer complies with the following general maintenance requirements:

- (a) The Product is maintained free from general debris or foreign matter.
- (b) The Product is maintained and serviced regularly (at least every 12 months) by a suitably qualified professional.
- (c) Where applicable, the Product is replaced at specified intervals as outlined in product literature by AQUEA.

2. Where applicable, Product has been used in pool or spa water which:

- (a) is maintained within a pH range of 7.2-7.6, and chemically balanced as per accepted industry standards.
- (b) is regularly (at least once a month) treated with a sanitising system in compliance with applicable regulatory recommendations or regulations.
- (c) has not exceeded 40 degrees Celsius in temperature.
- (d) has not been exposed to freezing conditions.

WARRANTY EXCLUSIONS

This warranty will not apply where:

- (a) the Product has not been installed in accordance with the installation instructions provided with the Product, any statutory requirements and these terms and conditions;
- (b) the Product has not been installed by a suitably qualified professional trained in the installation and operation of such products with more than 12 months industry experience;
- (c) a failure to observe and comply with the instructions supplied with product for the proper use, service or maintenance of the Product has occurred;
- (d) the Product has been used for a purpose other than that for which it was designed and manufactured;
- (e) removal or installation of the Product has contributed to, or resulted in, the defect or damage;
- (f) the Product has been repaired, altered or modified by someone other than AQUEA or its authorised agent;
- (g) substitute or replacement parts not provided by AQUEA have been used;
- (h) the defect has arisen due to abuse, misuse, neglect, or accident;
- (i) the Product has been subject to abnormal conditions, including environment, temperature, water, fire or other acts of nature;
- (j) the Product has been subject to abnormal corrosive conditions or abrasive chemicals;
- (k) the defect is the result of corrosion or normal wear and tear;
- (l) the defect is the result of insect and/or vermin infestation;
- (m) concrete, cement, render, pebbles or other pool surface finishes contribute to the defect, or inhibit proper function of the Product;
- (n) the damage occurred in transit;
- (o) after testing and inspection AQUEA cannot establish any fault in the Product;
- (p) the Product has been used in a commercial application;
- (q) the Product has not been supplied by AQUEA;
- (r) the defect is related to any cause other than a defect in the materials or workmanship of the Product.

LIMITATIONS

AQUEA makes no express warranties or representations other than set out in this warranty.

Except to the extent required by the Australian Consumer Law, the repair or replacement of the Product or part of the Product is the absolute limit of AQUEA's liability under this express warranty.

To the extent permitted by law, AQUEA will not be liable for:

- (a) Damage to any other property caused by defect in the Product.
- (b) Any indirect, special or consequential loss arising from or related to defects in the Product, including, but not limited to, loss of time, loss of use of the product, loss of business opportunity, loss of profits, loss of revenue, loss of goodwill, or inconvenience.
- (c) Any other damage as a result of weather or natural disaster.
- (d) Any claim against the customer by other parties.

Our goods come with guarantees that cannot be excluded under the Australian Consumer Law. You are entitled to a replacement or refund for a major failure and for compensation for any other reasonably foreseeable loss or damage. You are also entitled to have the goods repaired or replaced if the goods fail to be of acceptable quality and the failure does not amount to a major failure.

The benefits of this warranty are in addition to any rights and remedies imposed by Australian State and Federal legislation that cannot be excluded. Nothing in this warranty is to be interpreted as excluding, restricting or modifying any State or Federal legislation applicable to the supply of goods and services which cannot be excluded, restricted or modified.

CONTACT

For warranty claims visit www.aquea.com.au or contact AQUEA using details overleaf.

BUILD A
BETTER
POOL

AQUEA

WWW.AQUEA.COM.AU

AQUEA Pty. Ltd.
U12/22-24 REDLAND DRIVE, MITCHAM, VICTORIA 3132.
SALES & SUPPORT ENQUIRIES - HELLO@AQUEA.COM.AU
PHONE - 0481 875 870